



CHAIN CONVEYOR SOLUTIONS

Metal belt conveyors

Vibrating table

Waste conveyor

MARO WORLD INC

METAL BELT CONVEYOR P152

The **P152 conveyors** are made of a heavy type mechanically welded structure, and are fitted with a mat of flat blades, with a pitch of 152.4mm .

This type of conveyor is intended to be installed at the outlet of small shears, or behind a vibrating table.

MAIN FEATURES

	P152
Chain pitch	152 mm
Fracture resistance	12 000 daN
Usefull width	900mm to 1800mm
Lenght	On request



Technical details common to the 2 ranges (P152/P200)

Octagonal form for the reception area, for a better recovery of waste, no matter the position of the conveyor belt.

Raceway for the chains, in type «Train Rails». (green color on the diagram)

Stress rail, under the belt, in the center of the receiving area, to withstand shocks instead of the chain rollers, and thus improve its life expectancy. (purple color on the scheme)

Non-return plate, on the reception area, to prevent debris from returning to the rear articulation.

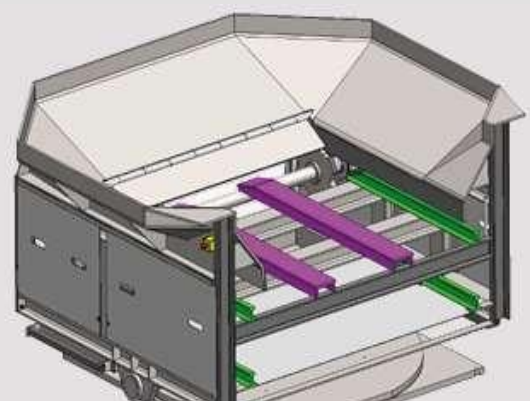

METAL BELT CONVEYOR P200

MAIN FEATURES

	P200
Chain pitch	200 mm
Fracture resistance	45 000 daN
Usefull width	1300mm to 2100mm
Lenght	On request

The P200 conveyors are manufactured like the P152, of a heavy welded structure, and fitted with a mat of flat blades, with a pitch of 200mm.

This type of conveyor is intended to be installed at the output of large shears.



Octagonal reception area, for better recovery of waste, in any position of the conveyor

Access stairway and walkway, in order to access the drive motor more easily

Raised edges, on the maintenance way side, to avoid any overflow on the maintenance way (Yellow color on the sketch)

System of earth recovery, trough 2 box

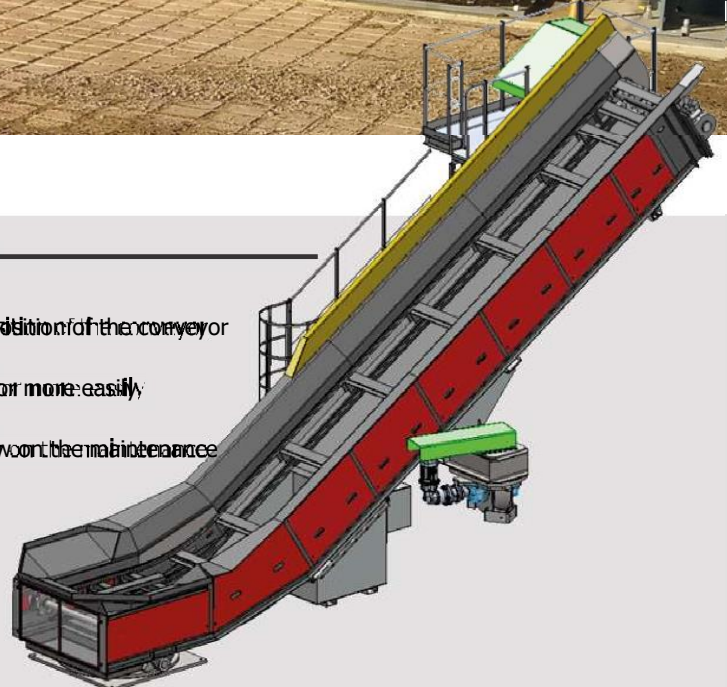

METAL BELT CONVEYOR P400



The **P400 conveyors** are fitted with a belt with folded blades, with a pitch of 400mm. This type of conveyor is used for feeding the shredder, transporting vehicles, etc.

MAIN FEATURES

Chain pitch	400 mm
Fracture resistance	89 000 daN
Usefull width	1800mm to 2400mm
Lenght	On request

P400





VIBRATING TABLE AND SORTING SOLUTION

It is possible to add, before the evacuation conveyor, additional devices, such as the vibrating table, screen, a waste conveyor, overhead. This is to separate the earth from the scrap.

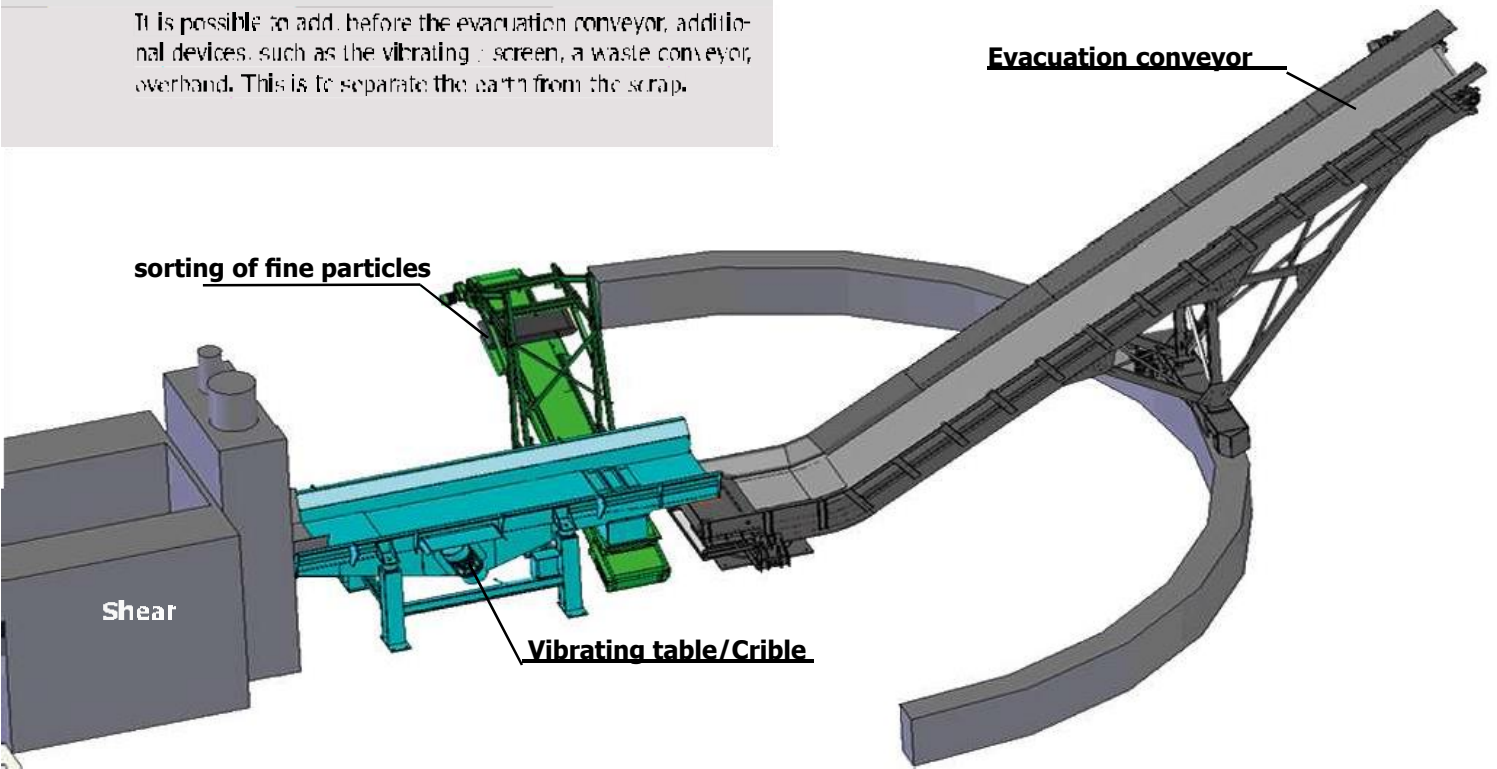

Vibrating table

Recommended at the output of the shear press, it reduces the impact of the product on the conveyor. Equipped with a screen, it facilitates the separation of fines (Soils, sands, etc.)

MAIN FEATURES

Usefull width	1100mm à 1800mm
Vibrating system	Unbalance motor
Isulation	By springs
Lenght	On request

TVB2

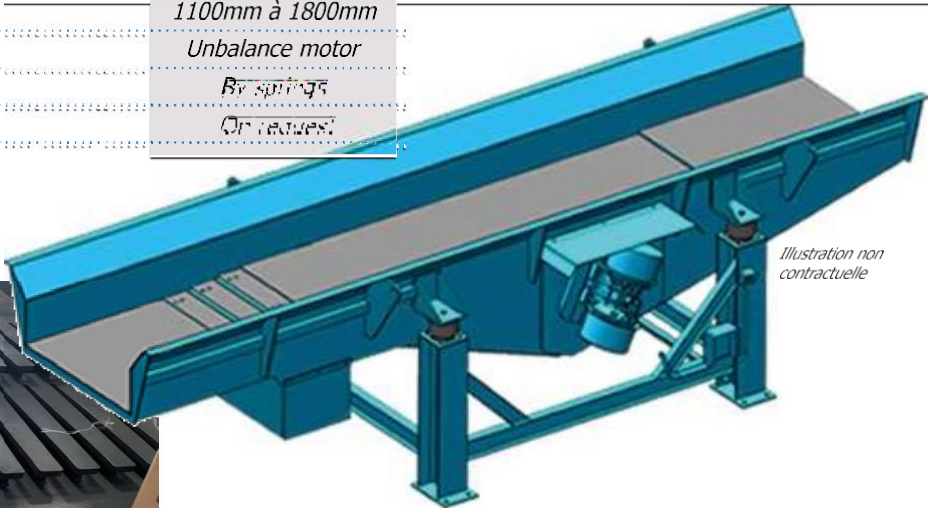

Illustration non contractuelle

Waste conveyor and Overband

Belt conveyor installed under the vibrating table screen. Its function is the handling of fines. Equipped with an electromagnet, it separates ferrous materials from fines

MAIN FEATURES

Usefull width	400mm à 1000mm
Band Type	Anti-Abrasion
Overband type	Permanent Magnet
Lenght	On request

TGA



VIBRATING TABLE AND SORTING SOLUTION

Details of the vibrating table



EXAMPLES OF MWI PRODUCTS

Sorting line



Conveyor at shear outlet



EXAMPLES OF MWI PRODUCTS

Conveyor of shredder



EXAMPLES OF MWI PRODUCTS

Scrap cleaner



CONVEYOR SOLUTIONS

Metal deck conveyors

Vibrating tables

Waste conveyor



MARO WORLD INC
WORLD OF HUMANS

MARO WORLD INC

Drage Todorovic 54, 34113 Kragujevac, Serbia

Office +381 60 6377551

Mail: office@maroworldinc.com / www.maroworldinc.com