



GLASS CRUSHER

MODEL 620

The High Volume, Conveyor Fed Glass Crushing Solution – Bottling Operations, Beverage Distributors, Recycling Operations and Municipalities

A high volume glass crusher designed for long life and trouble free operation. This model is capable of handling full or empty bottles. Conveyor Fed design with side flanges on belt and cover rails to contain material. This feature has been proven to greatly extend the life of the belt, eliminating some costly routine maintenance found on other crushers. Volume reductions up to 80%.

STANDARD PRODUCT FEATURES

- Rated capacities: 3 to 4 tons per hour
- Crushes up to and including one gallon containers
- Processes full or partially filled containers
- Factory-direct parts and service



SPECIFICATIONS

Machine constructed of heavy gauge steel
Designed for easy maintenance and upkeep
Replaceable crushing chamber
Reduces volume by 80%
½ HP crusher motor
½ HP conveyor motor
Crushed glass weight = 80 lbs. /cu. Ft.
16" wide conveyor bed
Features self-cleaning tail pulley
Replaceable rubber discharge shroud
Hardened replaceable crusher bar
Side flange belt

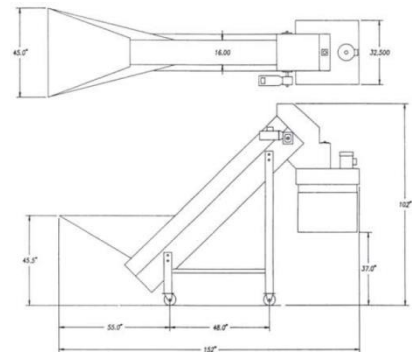

- **Length:** 12' 8"
- **Width:** 45"
- **Height:** 8' 6"
- **Weight:** 1,188 lbs.