

# LARGE GLASS CRUSHER



ENGINEERING SOLUTIONS FOR THE WASTE & RECYCLING INDUSTRIES

A solution to any business dealing with large quantities of glass bottles. The problem with this waste is the volume it takes up whilst in storage, it is also quite a noisy waste with any movement causing significant clinking sound which can be irritating to people in the immediate vicinity.

The MARO WORLD Glass crusher allows tipping skip loads to fill the hopper of this machine which then uses a conveyor to transport the bottles to a glass crushing unit which smashes the bottles into small particles and deposits them into a tipping skip.

- Easy to load bottles in via tipping skip or with automated controls from another conveyor
- Smooth operating conveyor moves bottles with minimal noise
- Large hopper ensures a full tipping skips volume of whole bottles is held, larger sides available to increase capacity
- Simple hammer design efficiently breaks glass with ease but also provides low running costs and ease of maintenance
- Crushed glass occupies a small fraction of its original size

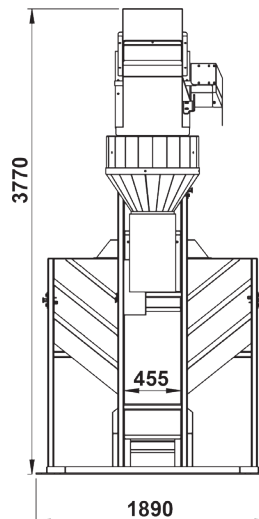
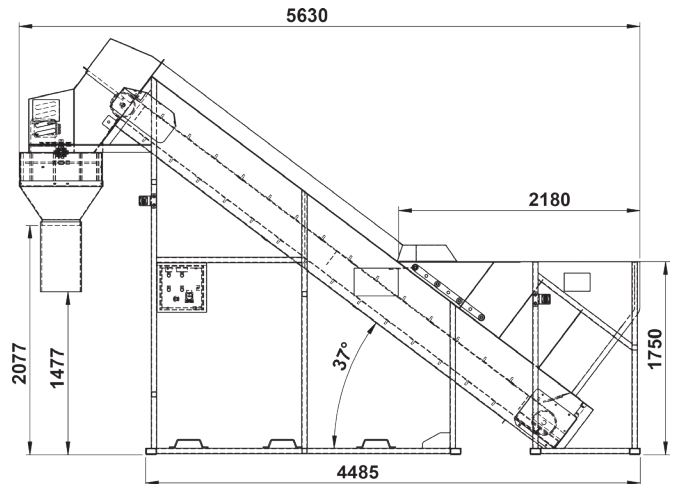

Power Supply: 415V 3 Phase

Machine Weight: 1200Kg

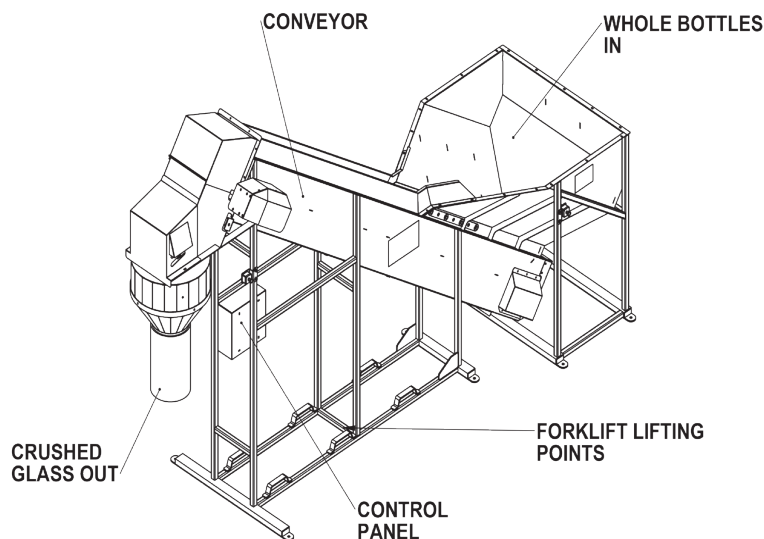

Drage Todorovic 54  
34000 Kragujevac  
Serbia



Email: [office@maroworldinc.com](mailto:office@maroworldinc.com)  
Phone: +381 60 6377551



[www.maroworldinc.com](http://www.maroworldinc.com)

